



# ...relieving the pain

The Jolly Back Chair is an innovative low seating solution for adults working at low heights. It improves posture, comfort and helps reduce the risk of musculoskeletal injury.



## What benefits does the Jolly Back Chair offer?

**As a unique purpose designed low chair, it can:**

- Relieve and prevent staff discomfort.
- Reduce the risk of staff acquiring sudden and/or long term musculoskeletal damage/injury.
- Improve staff wellbeing and morale, efficiency and pupil/patient/client care.
- Reduce staff sickness absence and early retirement due to ill health.
- Enable an organisation to demonstrate their Health and Safety commitment towards staff.



“Fills a huge gap in back care products we currently recommend to schools”

*County Council health and safety advisor*

# Why Jolly Back Chair has been developed

Many important professionals work at low heights – teachers, nursery nurses, childcare practitioners, midwives, children’s therapists, nurses, carers for example. Repetitive poor postures (bending over, over-stretching, twisting, awkward lifting, flexed sitting) are frequently adopted, as staff undertake the necessary low level activities required of them, day-in-day-out.

These repetitive poor postures, along with kneeling and squatting, are not only uncomfortable, but research highlights they are also damaging. This puts staff at an increased risk of acquiring musculoskeletal problems, in particular, back, hip, knee, neck and shoulder pain.

**The Jolly Back Chair has been specifically designed to reduce these damaging postures and promote healthy sitting – a low level seating solution is provided. Every feature has function, comfort and quality in mind.**

## Principles of Healthy Sitting Posture

- Head upright to maintain eye contact - neck and shoulders free to move with muscles relaxed
- Inward Lumbar (lower back) curve maintained - reduces back ache, slipped disks and sciatica. Assists correct neck alignment.
- Knees level or (preferably) slightly lower than hips - reduces hip compression/pain. Encourages natural lower spine alignment.
- Feet in contact with the floor - provides stability



## Unique Features

1. **Adjustable lower back support** - promotes good posture and provides individual comfort by reducing muscle tension
2. **Seat Wedge** - promotes natural upright posture, enables individuals to remain low down and provides cushioning.
3. **Extended handle** - allows positioning of the chair without lifting or bending over.
4. **Quality, swivel (lockable) wheels** - allow movement when seated to prevent twisting and over-reaching. Enables positioning of the chair without lifting and promotes safety.

“We really value and respect our staff; looking after their backs is essential”

*Primary School Head*

- Other Beneficial Features
- Compact for use where space is limited.
- Unobstructed floor space (under seat) allows easy movement when seated.
- 3 heights available
- Waterproof, breathable, anti-bacterial fabric in a range of colours
- Vinyl options available
- Developed by a Chartered Physiotherapist who specialises in paediatrics, occupational health and ergonomics, with input from front line staff.



# Product Technical Specification

**Weight limit:** 16 stone (102kg)

## STANDARDS

The Jolly Back Chair conforms to the following British Standards:

BSEN 1021:1 1994	Fabric flammability (cigarette test)
BSEN 1021:2 1994	Fabric flammability (match test)
BS 7176 1995	Fabric flammability (low hazard)
BS5852 1990	Flammability ignition source 5
BS4735 1974	CMHR foam flammability

## WARRANTY

Under normal wear and tear conditions, a 3 year manufacturer's warranty is provided.

## ENVIRONMENTAL IMPACT

The Jolly Back Chair is manufactured entirely within the UK, using processes to minimise its carbon footprint.

Please refer to [www.jollyback.com](http://www.jollyback.com) for full user information.

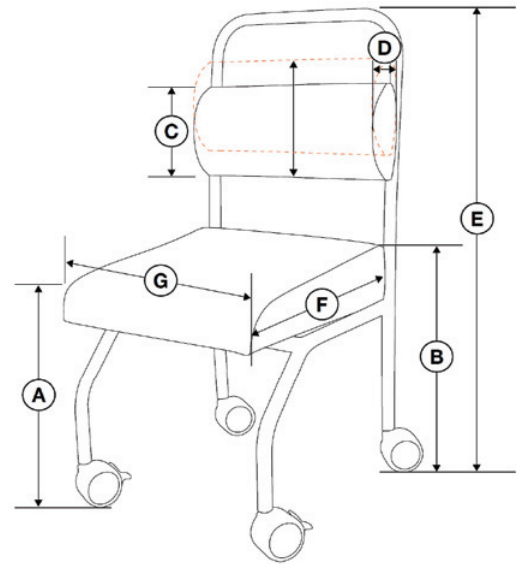

Size	Small	Medium	Large
A	350	365	400
B	390	405	440
C	150	150	150
D	55	55	55
E	790	790	790
F	380	380	380
G	350	350	350

All dimensions in mm

# Jolly Back Chair Size Guide

Adult User Height	Small	Medium	Large	Large
	2 - 4 yrs	4 - 6 yrs	6 - 8 yrs	6 - 8 yrs
≤160cm (5'3")	Small	Small	Small	Small
163cm (5'4")	Small	Small	Small	Medium
165cm (5'5")	Small	Small	Medium	Medium
168cm (5'6")	Small	Medium	Medium	Medium
170cm (5'7")	Medium	Medium	Medium	Medium
173cm (5'8")	Medium	Medium	Large	Large
175cm (5'9")	Medium	Large	Large	Large
≥178cm (5'10")	Large	Large	Large	Large

Sizes are a guide only

# Jolly Back Chair Fabric Colours

## STANDARD WATERPROOF FABRIC

Crimson Red - YW079



Deep Plum - YW211



Royal Blue - YW209



Sea Green - YW160



Black - YW009



## VINYL

Royal Blue - 00677



Sky Blue - 00566



Green - 16484



Colours shown are an indication only

[www.backcentre.co.uk](http://www.backcentre.co.uk)

# Don't just take our word for it

"Having worked in Education for over 12 years and suffered from lower back pain myself I don't think we can underestimate the importance of looking after teachers' backs. From constantly bending down to talk to children, leaning over desks, shifting desks and sitting on small chairs. Teachers' backs are really being put through their paces.

As a Healthy Schools Manager we advocate better health and wellbeing not only for children and young people but for all staff in school as well. By using the Jolly Back chair you should reduce staff absence and increase staff wellbeing."

*Louise Bates, Derby City Healthy Schools Programme Manager*

"All budgets are tight, I know ours is, but we are grateful to our Head for promoting staff wellbeing. My own back is definitely jollier after a term sitting on mine!

The chairs are easy to negotiate around busy classrooms, no fiddly bits to trap inquisitive fingers and fit under the lowest tables (I am 5'8" and 11st). I no longer feel as if I should hang from a door frame at the end of the day to stretch my contorted and aching lower back! The ultimate test of 3 hour parent evenings? Passed without a twinge."

*Sue Mousley, Reception teacher at Borrow Wood Infant and Nursery School*

## Lorna Taylor - the Jolly Back Chair's designer



Lorna is a Chartered and State Registered Physiotherapist. She is also a member of Association of Paediatric Chartered Physiotherapists (APCP), Association of Chartered Physiotherapists in Occupational Health and Ergonomics (ACPOHE) and professional member of BackCare – the Charity for Healthier Backs. Lorna has been working with the Derby City Healthy Schools Team since 2007 and works as an independent physiotherapist in her own children's physiotherapy practice.

Patent Application No. 0917099.4



The Back Centre has been supplying ergonomic seating, furniture and accessories for over 20 years. We supply to schools, colleges, universities, hospitals, local authorities, the emergency services and businesses as well as to the general public.

Finding appropriate and effective seating for primary and infant school teachers has long been a problem and so we are delighted to be able to supply The Jolly Back Chair. This simple but very effective chair should help teachers reduce the back problems associated with working with young children in the primary and infant classroom environment.

The Back Centre Ltd, Erme Court, Leonards Road, Ivybridge, Devon, PL21 0SZ  
T: 01752 893414 | E: [sales@backcentre.co.uk](mailto:sales@backcentre.co.uk) | W: [www.backcentre.co.uk](http://www.backcentre.co.uk)